

HOSHIZAKI

KM-150BAF
Item # 13073 9/03

KM-150B_F SERIES



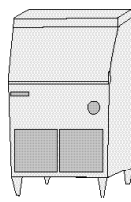

KM-150BAF
Air-Cooled
KM-150BWF
Water-Cooled

KM-150BAF



KM-150B_F

**ICEMAKER
DIMENSION**
Width x Depth x Height
KM-150B_F
25 x 28 x 39 1/8

- CycleSaver® design 
- EverCheck® alert system 
- Up to 158 lbs. of ice production per 24 hours
- Built in 70 lbs. ice storage
- Individual crescent cube
- Corrosion-resistant stainless and PVC exterior surfaces provide longer life
- Stainless steel evaporator
- Removable air filter

© HOSHIZAKI AMERICA, INC.

618 Hwy. 74 S., Peachtree City, GA30269

TEL1-800-438-6087

FAX 1-800-345-1325

www.hoshizaki.com



Reliability is a beautiful thing™

CRESCENT CUBER WITH BUILT-IN STORAGE BIN

KM150B_F SERIES

DIMENSIONS (Inches) - CONNECTIONS

CRESCENT CUBER WITH BUILT-IN STORAGE BIN

KM-150BAF (AIR-COOLED)
KM-150BWF (WATER-COOLED)

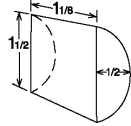

- Up to 158 lbs. of ice production per 24 hours
- Built in 70 lbs. of ice storage



WARRANTY THREEYEAR - Parts & Labor on entire machine. FIVEYEAR - Parts & Labor on: Evaporator FIVEYEAR - Parts on: Compressor; Air-Cooled Condenser Coil.	STAINLESS STEEL INTERNAL EVAPORATOR	SERVICE Panels easily removed and all components accessible for service. Removable/cleanable air filters.
	R-404 REFRIGERANT	

Warranty valid in United States, Canada, Puerto Rico, & U.S. Territories. Contact Factory for Warranty in other Countries.

STORAGE BINS Built-in 70 lbs. Storage Capacity	
OPERATING LIMITS Ambient Temp Range 45 - 100°F Water Temp Range 45 - 90°F Voltage Range 104 - 127V Water Pressure 10 - 113 psig	ELECTRICAL & PLUMBING AC Supply Voltage 115V/60/1 20 amp Max Fuse 1/2" OD copper or equivalent independent potable water supply 3/4" independent drain connection 1/2" FPT Water Inlet

AIR - COOLED				
Water Temp° F.	50°	70°	90°	
Air Temp° F.	70°	158	143	132
	80°	147	124	118
	90°	143	108	100

WATER - COOLED				
Water Temp° F.	50°	70°	90°	
Air Temp° F.	70°	140	134	125
	80°	135	125	117
	90°	134	118	110

UTILITY CONSUMPTION					
Model Number	Ice Production Per Cycle		KWH per 100 lbs.	Potable Water Gallons per 100 lbs.	Condenser Water Gallons per 100 lbs.
	Lbs.	Cubes			
KM-150BAF	2.6	130	13.7	31.6	NA
KM-150BWF	2.6	130	10.9	28.9	171

SPECIFICATIONS				
Model Number	Condenser	Amperage	Min. Circuit Ampacity	Shipping Weight
KM-150BAF	Air-Cooled	8	20	215 lbs.
KM-150BWF	Water-Cooled	7.5	20	215 lbs.

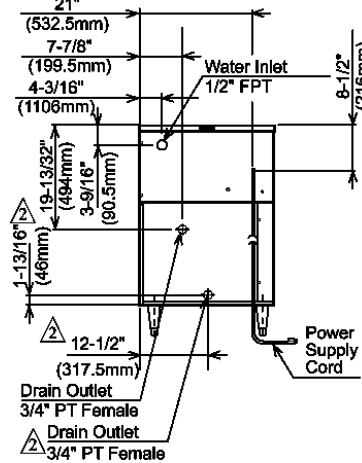

Rated in accordance with ARI Standard 810-95

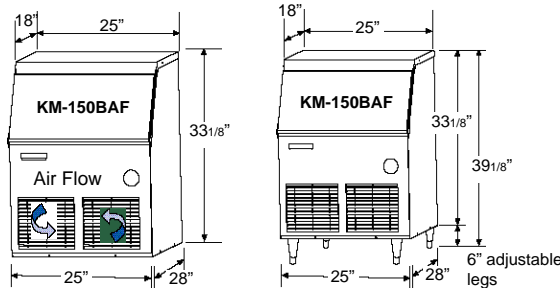
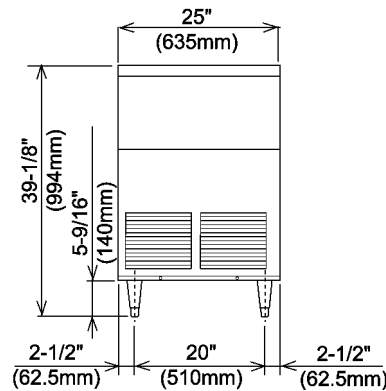
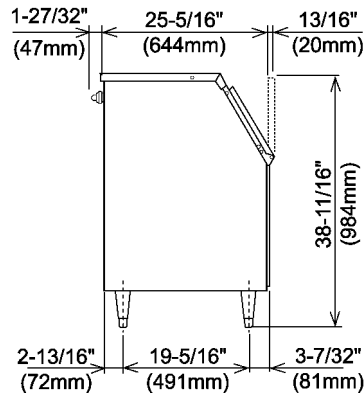

We reserve the right to change specifications without notice.